

# Introducing Bonar Plastics new line of Small Insulated Boxes

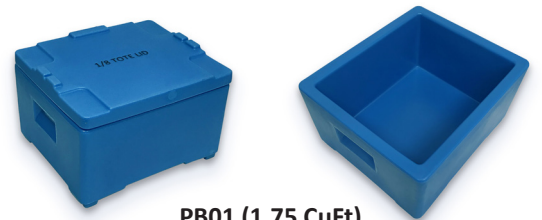

**PB01 (1.75 CuFt)**



**PB03 (3.5 CuFt)**



**PB07 (8.75 CuFt)**



- (3) New sizes- **PB01** (1.75 CuFt), **PB03** (3.5 CuFt), **PB07** (8.75 CuFt)
- Manufactured with FDA/Health Canada compliant resins
- New integrated gasket in lid to reduce thermal loss
- Boxes stack together to maximize cube
- Integrated handles for ease of handling
- Boxes smooth, with radiused corners for ease of cleaning
- Boxes do not have drains, easily dumped by hand
- Boxes filled with 2 lb. PUR Foam (Polyurethane) / R-value 7 per inch

[www.bonarplastics.com](http://www.bonarplastics.com)

402.467.5221 | 1.800.768.6246

Made in the USA



**1.75 CuFt**  
PB01



**Weight:**

30 lbs.

**Internal Dimensions:**

L: 19.1"

W: 15.6"

H: 10.6"

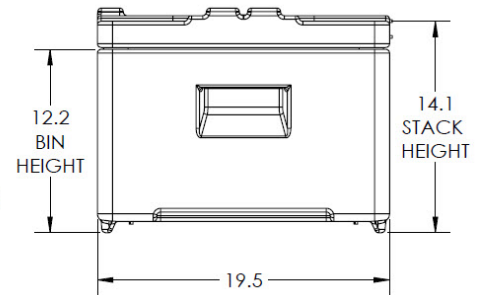
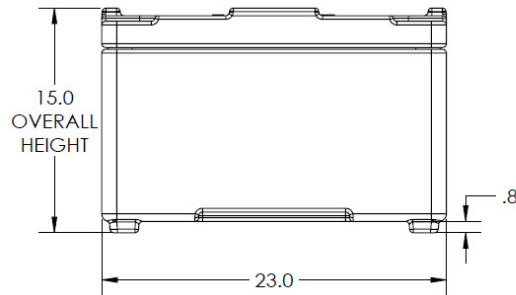

**3.5 CuFt**  
PB03



**Weight:**

41 lbs.

**Internal Dimensions:**

L: 18.0"

W: 14.5"

H: 22.1"

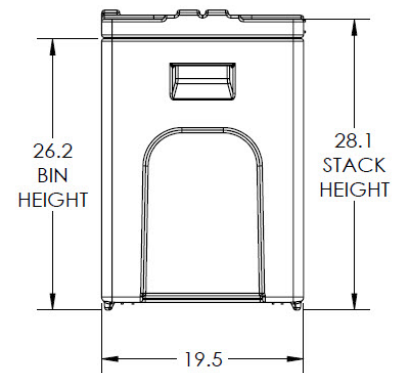
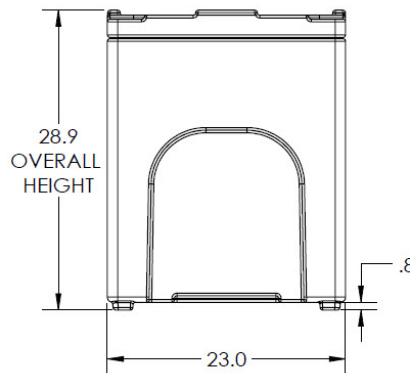

**8.75 CuFt**  
PB07



**Weight:**

79 lbs.

**Internal Dimensions:**

L: 33.7"

W: 19.2"

H: 22.1"

