



DRUMS *with MOLDED-IN HANDLES*

- Made from tough, impact resistant polyethylene.
- Molded handles (on both sides of drum) allow for easy handling of materials.
- Seamless interior; easy to clean.
- Easily accommodates bags or liners.
- Can be manufactured in a wide selection of FDA compliant translucent and opaque colors.
- Standard drum wall thickness is 0.180".
- Wall thickness can be modified to accommodate a more demanding application.
- Drums can be produced with FDA compliant antistat material to reduce static build up.
- Meet or exceed USDA and FDA requirements.



- Lever lock lids with plastic lever lock rings or dust covers are available.
- Lever locking rings are corrosion proof and provide tamper resistance.
- Lid design facilitates stacking without any shifting.

| Item Number | Outside Diameter Dia. x Ht. " | Weight (lbs.) | Capacity (Gal.) |
|-------------|-------------------------------|---------------|-----------------|
| 3MH-NBC* | 14 X 7 | 3 | 3 |
| 10MH-NBC* | 17 X 16 | 9 | 10 |
| 15MH-NBC* | 17 X 21.75 | 10.5 | 15 |
| 30MH-SBC | 19 X 31 | 13 | 30 |
| 40MH-NBC* | 21.5 X 32 | 18 | 40 |

*Nestable
All stackable with lid

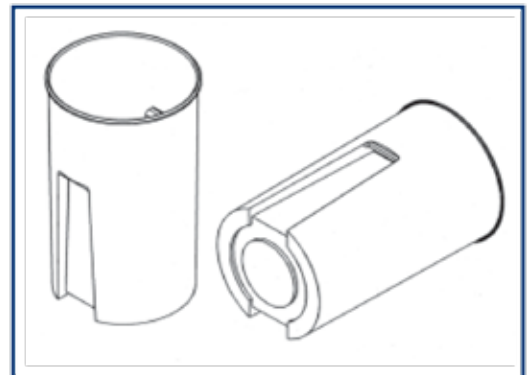

6940 "O" Street, Suite 100 • Lincoln, Nebraska • 68510 • Customer Service: 800-768-6246 • Fax: 402-465-1220
Other manufacturing locations: Marked Tree, Arkansas • Philippi, West Virginia • Chowchilla, California

www.bonarplastics.com